

GeN2Mod 4:1

OTIS

United Technologies



THE WAY TO GREEN™



Modernization, customized solutions, exceptional results

PRODUCT ADVANTAGES

- Very high efficiency of GeN™ technology
- Belts lasting 2-3 times longer than conventional steel ropes with no need of lubrication
- Dramatic reduction of wear and increase of durability thanks to smooth crowned sheaves and the reduction of moving parts in the gearless machine
- Low power consumption – either non-regenerative machine or regenerative machine
- Reduced noise level and improved running comfort with noticeably smoother acceleration and deceleration
- Pulse system constantly monitors the belts 24/7 to ensure that the maximum life cycle is achieved
- Improved floor levelling and ride quality

Otis brings extensive experience, expertise and a full complement of innovative solutions and cutting-edge technologies to customers who look to improve performance, reduce energy consumption and green existing properties.

Moving up to green is easy with advanced Gen2 technology

Solutions like our Gen2 Mod package make it easy to increase the value of existing properties while raising the bar in terms of performance, comfort and appearance. The Gen2 Mod solution lets older buildings benefit from increased energy efficiency and substantial cost savings by taking full advantage of the latest green technologies, including Otis' polyurethane-coated flat-belts, compact and highly efficient gearless machines, ReGen drives and LED lighting. Otis' solutions can also help eliminate the hundreds of gallons of oil some systems use for lubrication by incorporating new technologies that do not require any additional lubrication.

Range of application GeN2™ Mod 4:1 roping

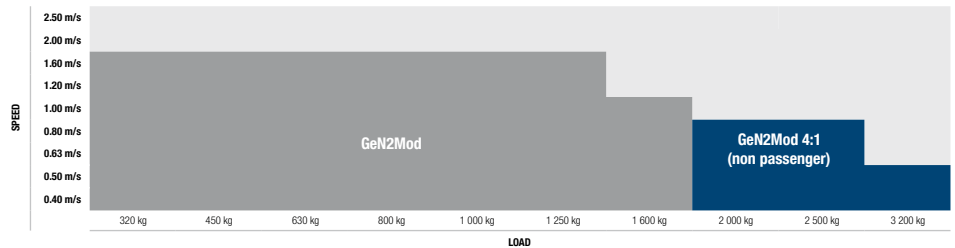

TECHNICAL PARAMETERS

Parameter	Minimum	Maximum	Remark
Type of the lift	Traction lift		Regenerative machine and drive after modernization is standard, symmetric shaft layout only
Roping	4:1		Possible modernization for lift with 1:1 roping but new position of holes for slab are necessary
Speed	$\leq 0,80$ m/s for load $\leq 2\,500$ kg $\leq 0,50$ m/s for load $\leq 3\,200$ kg		Depends on load
Load	$\geq 1\,000$ kg $\leq 3\,200$ kg		Higher load must be verified by supplier
Operation controller	SAPB (simple) / DCL (down-collected) / FCL (full-collected)		–
Units in group	1	5	–
No. of stops	≤ 10 stops / openings / simplex (G1C) ≤ 50 stops / openings / quintex (G5C)		Depends on door operator type
Rise	$\leq 33,5$ m		Rise has an impact into drive specification
Power (max.)	5 kW	9 kW	Depends on lift characteristic
Starts per hour	150	240	Starts per hour depends on drive / speed
Flight time (3m run)	7 sec		–
Stopping accuracy	± 5 mm		–
Floor distance	0,38 m	12 m	Unlimited number of short landing are possible
Power supply	380V / 400V / 415V, 3Ph, 50 Hz		–
Earthing	TN-C (four wire net – local modification required)	TN-S (five wire net)	–
Number of car entrances	1	2	
Door arrangement	Automatic – automatic (central opening) CLD Automatic – automatic (side opening) TLD Automatic – manual (no retiring cam) ACG-1 Automatic – manual (with retiring cam) ACG-2		Depends on lift characteristic
Door operators	AT120 / D05 / D05-EM / D0C9 /10/12/25/27/28/29 /30/ 40/ DOT-1		D02000 requires replacement to D05EM, DOT-2 requires replacement to GMP900 with AT120 or GMP1100 with D0C25
Car door detectors	IRC or LRD		30 Vdc / 110 Vac and 230 Vac requires application of GCS2112MMR controller
Car position indicators	CPI 7/10/11/15/16/18/18B/21		CPI7/12 adjustable on jobsite
Hall position indicators	HBHPI + HPI7/10/11/12/13/14/15/18		HPI7/10/11/12 adjustable on jobsite
Additional advantages	Manual electrical rescue operation / Standby power consumption for controller is about 55W / Remote Elevator Monitoring system / Unintended Car Movement Protection (EN 81-1 +A3) / Emergency Hospital Service / Emergency Fireman Service / Emergency Power Operation		Additional power consumption must be added when peripheral components like car and hall link fixtures, traveling cable, safety chain, car light in use and very much depends on individual installation parameters

LOW POWER CONSUMPTION

The Gen2 Mod 4:1 solution delivers energy savings of up to 75 percent compared to conventional systems, saving operational costs and ensuring efficient performance. The motor for such capacity lifts is usually above 15kw but in

our newly developed product we use a 9kw power rate and regenerative drive system is standard. It gives to customer reasonably lower power consumption with keeping higher efficiency due to better traction on belts.

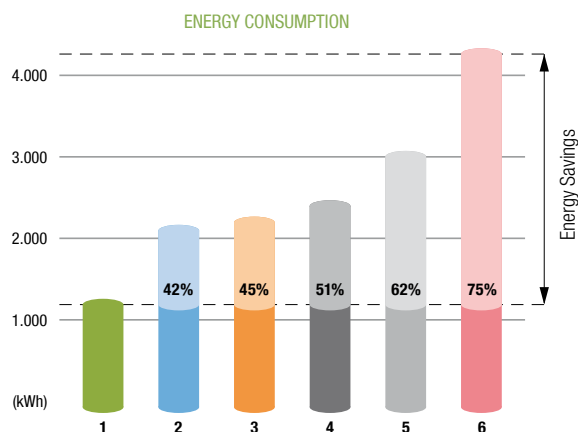
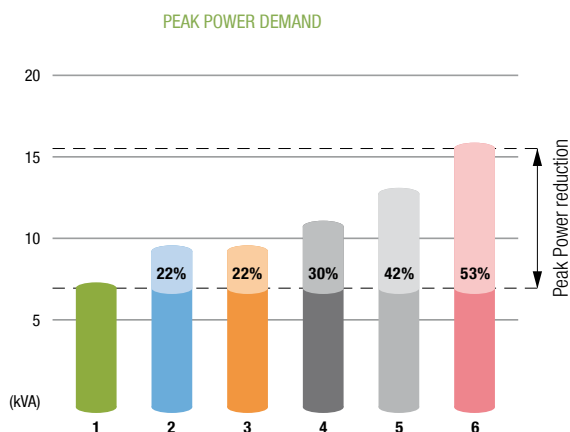

● GeN2 with ReGen drive ● GeN2 with non-regen drive ● Gearless induction motor ● Gearless PMSM motor axial design ● Geared induction motor ● Hydro
 These graphs represent energy consumption of machine and drive. Graphs do not include energy for door operators, lighting, controller, fan and other features.

NOISE LEVEL REDUCTION

The Gen2Mod 4:1 modernization pack is designed with passenger and transport goods comfort in mind. Careful component design and selection enabled Otis to engineer a remarkably smooth and quiet Lift. This means a more comfortable passenger experience as well as the quiet operation that is critical to those tenants located near the system. This mainly helps to use this product for hospitals, commercial centres and also for buildings where customer expect to keep or reduce noise level from the system.

IMPROVED FLOOR LEVELLING AND RIDE QUALITY

4:1 roping system in combination with new position reference system offer to customer very precise floor levelling and therefore improves loading process through operation. Ride quality of the lift is ensured by OTIS frequency drive and alignment of guide rails together with combination of correct setup for position reference system.

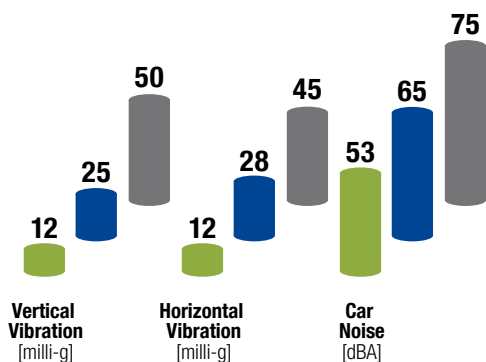

● INDUSTRY HYDRAULIC SYSTEM ● INDUSTRY GEARED SYSTEM ● GEN2™ SYSTEM

INDUSTRY COMPARISON

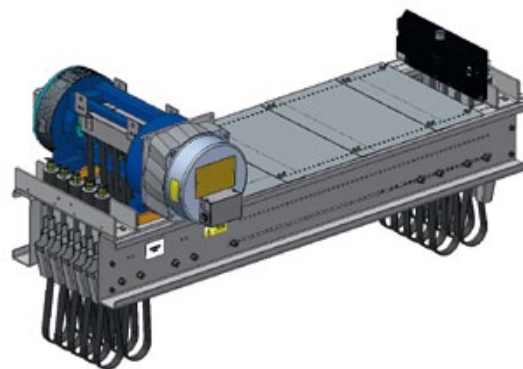

www.otis.com



Otis reserves the right to change any part of this specification without prior notice.
The product colors in this brochure are representative not exact.
All rights reserved.